

# Microwave Photonic Systems, Inc. 888-868-8967

## MPS-2100 Singlemode, Inline Optical Attenuator

- In-line Configuration
- All Fiber Construction (no air gap utilized)
- Single Window or Dual Window Capability
- Fixed Attenuation Values from 1 to 40 dB
- Environmentally Stable
- Telcordia Compliant for Endface Geometry

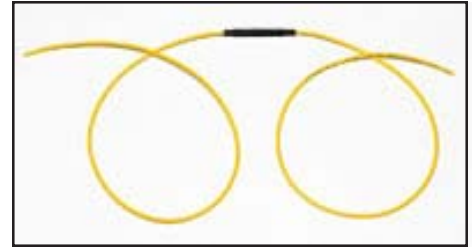

### Description:

The MPS-2100 Singlemode In-line Optical Attenuator is a “fixed value” attenuator that is integrated into a standard fiber optic jumper cable. The MPS-2100 utilizes Corning singlemode SMF-28 fiber and can be configured with various cable jacketing diameters. The In-Line Attenuators are available in either single window or dual window configurations with attenuation values up to 40 dB in 1 dB increments. The attenuators are available in fiber diameters of 250 micron, 900 micron, 2mm or 3mm and come integrated into any length jumper. It can be supplied with or without connectors, or as a pigtail version. In addition, each terminated attenuator assembly meets Telcordia standards and is tested for insertion and return loss.

### Specifications:

Parameter	Single Window Wideband	Dual Window Wideband
Attenuation	1 to 40 dB, ± 5%	1 to 40 dB, ± 5%
Operating Wavelength	1310 nm ± 50 nm or 1550 nm ± 50 nm	1310 nm ± 50 nm and 1550 nm ± 50 nm
Back Reflection	≤ -65 dB	
Polarization Loss (PDL)	< .15 dB	
Operating Temperature	-40°C to +85°C	
Fiber Type	Singlemode; SMF-28 or DS	
Fiber Pigtail Type	250 μm Bare, 900 μm Buffered, 2mm or 3 mm Furcated	

### Applications:

- Fiber Optic Amplifiers
- Optical Sensors
- High Speed Data Networks
- CATV Systems
- Telecommunications
- RF Optical Links

### Part Number Generator:

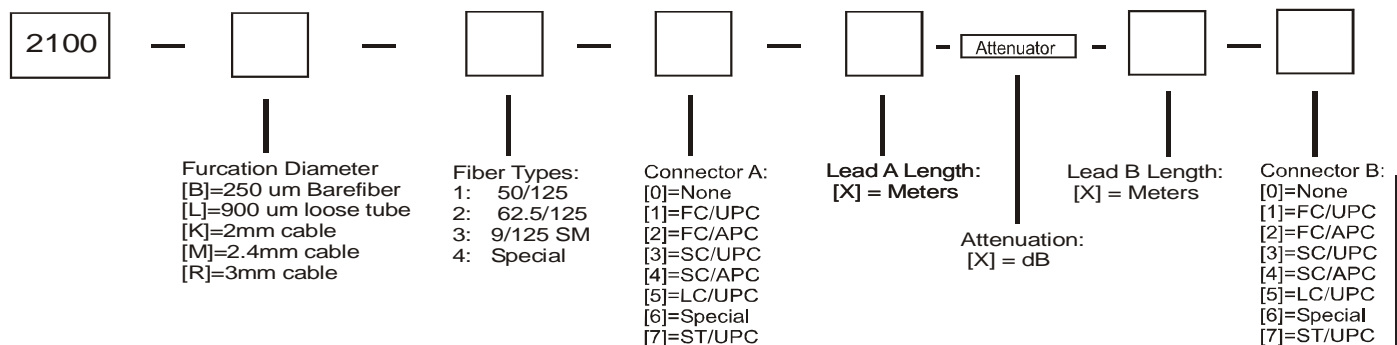

SM IN-LINE ATTENUATOR



www.b2bphotonics.com  
 Microwave Photonic Systems, Inc.  
 882 South Matlack St., Unit 104  
 West Chester, PA 19382

Toll Free: 888-868-8967  
 Phone: 610-344-7676  
 Fax: 610-344-7110  
 e-mail: info@b2bphotonics.com